

ESX.4cl-ag

ESX control units

KEY FEATURES

- Control specially designed for use in harsh mobile applications
- Flexible programming in C, Matlab¹⁾ or IEC61131-3 (logi.CAD 3)
- Suitable for safety-related applications up to SIL2 according to IEC 61508:2010¹⁾, PL d according to EN ISO 13849-1:2015¹⁾, AgPL d Cat 2. according to DIN EN ISO 25119¹⁾ or ASIL B according to ISO 26262¹⁾

¹⁾Scheduled feature

TECHNICAL DATA

- Aurix TC399 Multicore 32 bit, 300 MHz
- Internal: 6.5 MB RAM, 16 MB Flash
- External: optional data flash and F-RAM options
- 256 kB F-RAM
- 6 CAN interfaces, 1 RS232 or LIN
- 2 100/1000BASE-T1, 1 100BASE-T1 and 1 100BASE-TX Ethernet interfaces
- 58 inputs
- 59 outputs
- Coprocessor i.MX 6 with Linux (optional)

ACCESSORIES

- Debug device of the controller
- Debugger
- Compiler
- Starter kit
- Component deployment C, Matlab¹⁾, and IEC61131-3 (logi.CAD 3)
- Mating plug
- Integrated into STW's openSYDE software platform

Sensor-Technik Wiedemann GmbH

Am Bärenwald 6
87600 Kaufbeuren
Germany
+49 8341 9505-0
info.stw@wiedemann-group.com
www.stw-mm.com

BLOCK DIAGRAM

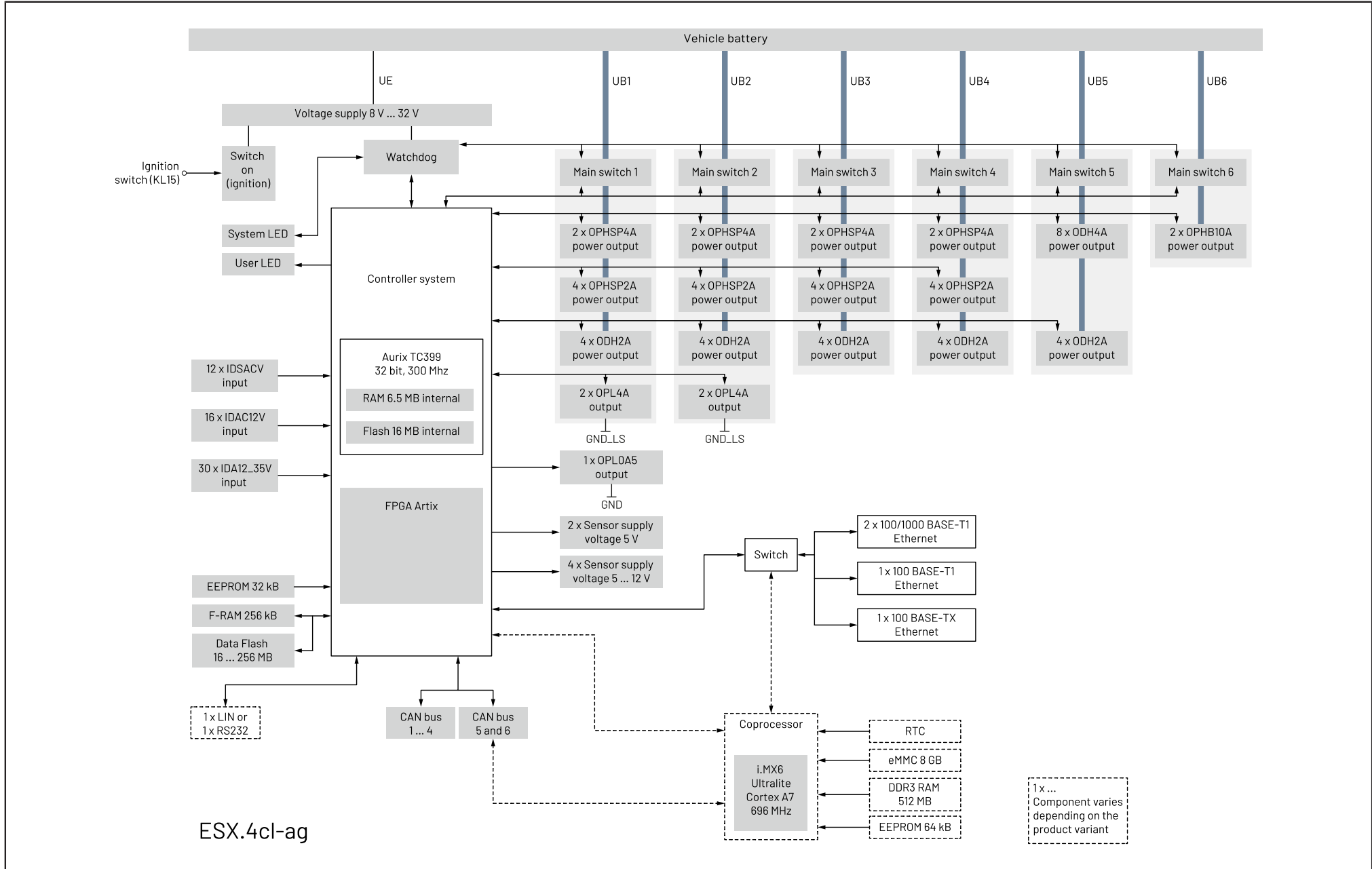

Variants

Variant features of the ESX.4cl-ag

Feature		Variant 1	Variant 2
Processor and memory	32 bit Infineon Aurix TC399 multicore CPU, @ 300 MHz	✓	✓
	6.5 MB internal RAM	✓	✓
	16 MB internal Flash	✓	✓
	16 MB external data Flash	✓	✓
	256 kB F-RAM	✓	✓
	i.MX6 UltraLite 32-bit MPU, ARM Cortex-A7 core, 700MHz	–	–
	512 MB DDR3 RAM	–	–
	8 GB eMMC	–	–
	64 kB EEPROM	–	–
	Real Time Clock (RTC)	–	–
Communication interface	CAN, from 100 kbit/s to 1 Mbit/s	6	4
	100/1000BASE-T1 Ethernet	2	2
	100BASE-T1 Ethernet	1	1

Variant features of the ESX.4cl-ag

Feature		Variant 1	Variant 2
	100BASE-TX Ethernet	1	1
	RS232 or LIN	1	1
Inputs	IDSACV	12	12
	IDAC12V	16	8
	IDA12_35V	30	16
Outputs	Digital/PWM high side output OPHSP4A	8	4
	Digital/PWM high side output OPHSP2A	16	8
	Digital output ODH4A	8	6
	Digital output ODH2A	20	8
	PWM half bridge output OPHB10A	2	2
	Digital/PWM low side output OPL4A	4	2
	Digital/PWM low side output OPL0A5	1	1
	Sensor supply voltage 5 V	2	2
	Sensor supply voltage 5 ... 12 V	4	4

Variants

Available options of the ESX.4cl-ag

Options

Communication Interface

LIN in accordance to LIN specification 2.2 A (with equipped i.MX6 the LIN option is not available)

TECHNICAL DATA

Processor and memory

Type	Properties	Features
Aurix TC399	32 bit, multicore processor, @ 300 MHz	<ul style="list-style-type: none"> External system supervisor with programmable watchdog 12 bit A/D converter for analog signal processing
Flash	16 MB	15.5 MB available for customer application
Data Flash	16 MB	
RAM	6.5 MB	On-chip RAM This memory serves as system memory for BIOS stack and data. In addition roughly 80 % can be used for the customer application.
FRAM	256 kB	Available for customer application. FRAM data retention: <ul style="list-style-type: none"> 11 years at 105 °C 121 years at 85 °C Typical endurance according to manufacturer: 10 ¹³ read/write cycles at 125 °C

Processor and memory coprocessor (optional)

Type	Properties	Features
i.MX 6UltraLite	32 bit controller @ 696 MHz	Single ARM Cortex®-A7 core
RAM	512 MB DDR3	On-chip ECC
eMMC memory	8 GB	Write endurance in total terabyte written (TBW): 20 TBW Data retention (fresh or early life device): 15 years at 55 °C Data retention (after 3K PE cycles): 20 month at 55 °C
EEPROM	1 x 64 kB	-
RTC	Accuracy: ±6 ppm at -40 °C to +85 °C	Buffering time for minimum 5 minutes
Temperature measurement	Accuracy: ±2 °C at -40 °C to 150 °C	Located close to coprocessor and RAM

TECHNICAL DATA

Communication interfaces

Type	Maximum quantity	Configuration
CAN	6	CAN 2.0B, baud rate from 100 kbit/s to 1 Mbit/s
Ethernet	2	100/1000BASE-T1 (100 Mbit/s/1 Gbit/s Single Pair Ethernet)
	1	100BASE-T1 (100 Mbit/s Single Pair Ethernet)
	1	100BASE-TX (100 Mbit/s Ethernet)
RS232	1	Baud rate up to 115 kBit/s
LIN (optional)	1	In accordance to LIN specification 2.2A

- LIN and RS232 share the same connector pins, i.e. either RS232 or LIN is available, but not both.
- If the i.MX6 coprocessor is equipped, RS232 is operated by the i.MX6.

TECHNICAL DATA

Inputs

Type	Maximum quantity	Possible configuration	Measurement
Multifunctional input 12 V and 35 V IDA12_35V	30	Analog voltage programmable	0 ... 35 V 0 ... 12 V
		Programmable pull-up resistor	1.1 kΩ to +8.5 V
		Programmable pull-down resistor	1 kΩ to GND
		NAMUR sensor	NAMUR sensor compatible
		Digital	Active-high/Active-low
		Frequency	0.6 Hz ... 20 kHz
		Incremental encoder interface	Change of position or angular change
		Multifunctional input IDSACV	12
		Analog current	0 ... 24 mA
		Programmable pull-up resistor	1.1 kΩ to +8.5 V 10 kΩ to +5 V
		Programmable pull-down resistor	1 kΩ to GND
		NAMUR sensor	NAMUR sensor compatible
		Digital (voltage mode)	Active high Active low
		Frequency	0.6 Hz ... 20 kHz
		Incremental encoder interface	Change of position or angular change
		SENT	Full SENT interface at voltage measuring range 0 ... 5 V
Multifunctional input IDAC12V	16	Analog voltage	0 ... 12 V

TECHNICAL DATA

Inputs

Type	Maximum quantity	Possible configuration	Measurement
		Analog current	0 ... 24 mA
		Programmable pull-up resistor	1.1 kΩ to +8.5 V
		Programmable pull-down resistor	1 kΩ to GND
		NAMUR sensor	NAMUR sensor compatible
		Digital (voltage mode)	Active high Active low
		Frequency	0.6 Hz ... 20 kHz
		Incremental encoder interface	Change of position or angular change

Outputs

Type	Maximum quantity	Possible configuration	Range	Characteristics	Feature
Digital/PWM high side output OPHSP2A	16	PWM	0 ... 2.5 A	0 ... 100 % Duty cycle resolution < 0.1 % PWM frequency 20 ... 1000 Hz	<ul style="list-style-type: none"> High side switch Precise current measurement, accuracy is ±2.3 % ±35 mA Supports current control mode Digital feedback, open load detection in OFF state Automated shutdown on overcurrent > 4.6 A ±0.9 A Combine several outputs for parallel operation
		Digital	-	ON/OFF	
Digital/PWM high side output OPHSP4A	8	PWM	0 ... 4 A	0 ... 100 % Duty cycle resolution < 0.1 % PWM frequency 20 ... 500 Hz	<ul style="list-style-type: none"> High side switch Precise current measurement, accuracy is ±2.3 % ±70 mA Supports current control mode Digital feedback, open load detection in OFF state
		Digital	-	ON/OFF	

TECHNICAL DATA

Outputs

Type	Maximum quantity	Possible configuration	Range	Characteristics	Feature
Digital output ODH2A	20	PWM	0 ... 2.5 A	0 ... 100 % Duty cycle resolution < 0.1 % PWM frequency 20 ... 1000 Hz	<ul style="list-style-type: none"> Automated shutdown on overcurrent > 7.5 A ±1.5 A Combine several outputs for parallel operation
		Digital	-	ON/OFF	
Digital output ODH4A	8	PWM	0 ... 4 A	0 ... 100 % Duty cycle resolution < 0.1 % PWM frequency 20 ... 1000 Hz	<ul style="list-style-type: none"> High side switch Optimized for digital operation mode (ON/OFF) Current feedback, measurement accuracy is ±25.0 % (gain) ±100 mA (offset) Output voltage feedback, voltage measurement with ±3 % (gain) ±0.15 V (offset) Automated shutdown on overcurrent > 3.6 A ±0.9 A Combine several outputs for parallel operation up to 15 A
		Digital	-	ON/OFF	
Digital/PWM low side output OPL4A	4	PWM	0 ... 4 A	0 ... 100 % Duty cycle resolution < 0.1 % PWM frequency 20 ... 1000 Hz	<ul style="list-style-type: none"> Low-side switch Precise current measurement, accuracy is ±2.3 % ±100 mA Supports current control mode Digital feedback, open load detection in OFF state
		Digital	-	ON/OFF	

TECHNICAL DATA

Outputs

Type	Maximum quantity	Possible configuration	Range	Characteristics	Feature
					<ul style="list-style-type: none"> Automated shutdown on overcurrent > 7.5 A ±0.9 A Output voltage feedback, accuracy is ±4.5 % ±200 mV
Digital/PWM half-bridge output OPHB10A	2	PWM	0 ... 10 A	0 ... 100 % Duty cycle resolution < 0.1 % PWM frequency 5 ... 20000 Hz	<ul style="list-style-type: none"> Push-pull output Current measurement ±2.3 % ±200 mA Supports current control mode Digital feedback Output voltage feedback, accuracy is 3 % ±150 mV Automated shutdown on overcurrent > 32 A ±15 A Automated shutdown on overtemperature Two half-bridge outputs might be combined as full-bridge
Digital low side output OPL0A5	1	PWM	0 ... 0.5 A	0 ... 100 % Duty cycle resolution < 0.1 % PWM frequency 20 ... 1000 Hz	<ul style="list-style-type: none"> Low-side switch Output voltage feedback, accuracy is ±4 % ±200 mV
		Digital	-	ON/OFF	
Main Switch	6		8 ... 32 V DC	ON/OFF	<ul style="list-style-type: none"> High-side switch switches the output groups +UB1 to +UB6 Current up to 12 A
Sensor supply voltage 5 V	2	-	5 V	ON/OFF Accuracy voltage output is +2 ... ±1.5% Accuracy voltage readback is ±2.5% ±50 mV	Maximum output current 250 mA
Sensor supply voltage 5 ... 12 V	4	Voltage	5 ... 12 V	Accuracy voltage output is ±0.9% ±50 mV This is valid under the following conditions:	Maximal output current I _{MAX} = 250 mA

TECHNICAL DATA

Outputs

Type	Maximum quantity	Possible configuration	Range	Characteristics	Feature
				<ul style="list-style-type: none"> Capacitive load $\leq 470 \mu\text{F}$ Settling time 100 ms Accuracy voltage readback: $\pm 0.9\% \pm 50 \text{ mV}$	Programmable output needs derating for output voltages $U_{\text{EXT}} < 10 \text{ V}$: $I_{\text{MAX}} = 0.875 / (13.5 - U_{\text{EXT}}) \text{ A}$

Mechanical data

Component	Description	Value
Connectors	-	Automotive 154 pins, Molex CMC Ethernet, M12 connector: 2x 100/1000BASE-T1: 2 pins, IEC63171-5 1x 100BASE-T1: 2 pins, IEC63171-5 1x 100BASE-TX: 4 pins, D-type
Indicators	2 LED, dual color (red/green or mixed colors)	System LED and User LED
Housing	Die-cast aluminum	GORE-TEX™-breathing filter for pressure equalization
Degree of Protection	Variant without M12 Ethernet connector	IP6K6, IPX7, IPX9K
	Variant with M12 Ethernet connector	IP6K5, IPX7
Dimensions	-	264 mm x 260 mm x 55 mm
Operating temperature, housing temperature	-	-40 ... +85 °C (-40 ... +185 °F)
Operating altitude	-	-400 ... +4000 m

TECHNICAL DATA

Power supply

Component	Description	Range	
		Minimum Value	Maximum Value
DC voltage supply	Voltage at +UE ECU supply and +UB power supply	8 V DC	32 V DC
Current consumption	Power supply +UB1 fully loaded 12 A	-	60 A, short-term
	Power supply +UB2 fully loaded 12 A	-	
	Power supply +UB3 fully loaded 12 A	-	
	Power supply +UB4 fully loaded 12 A	-	
	Power supply +UB5 fully loaded 12 A	-	
	Power supply +UB6 fully loaded 12 A	-	
	4 x low side output OPL4A	-	
Standby	Sum of input currents at +UE and +UB ($U_{KL15} = 0\text{ V}$, ignition off) Without external load		< 1 mA (max. 28 V)
ECU active	+UE supply current ($U_{KL15} > U_{KL15HIGH}$, no external load)		≈ 500mA at +UE = 12 V ≈ 300mA at +UE = 28 V

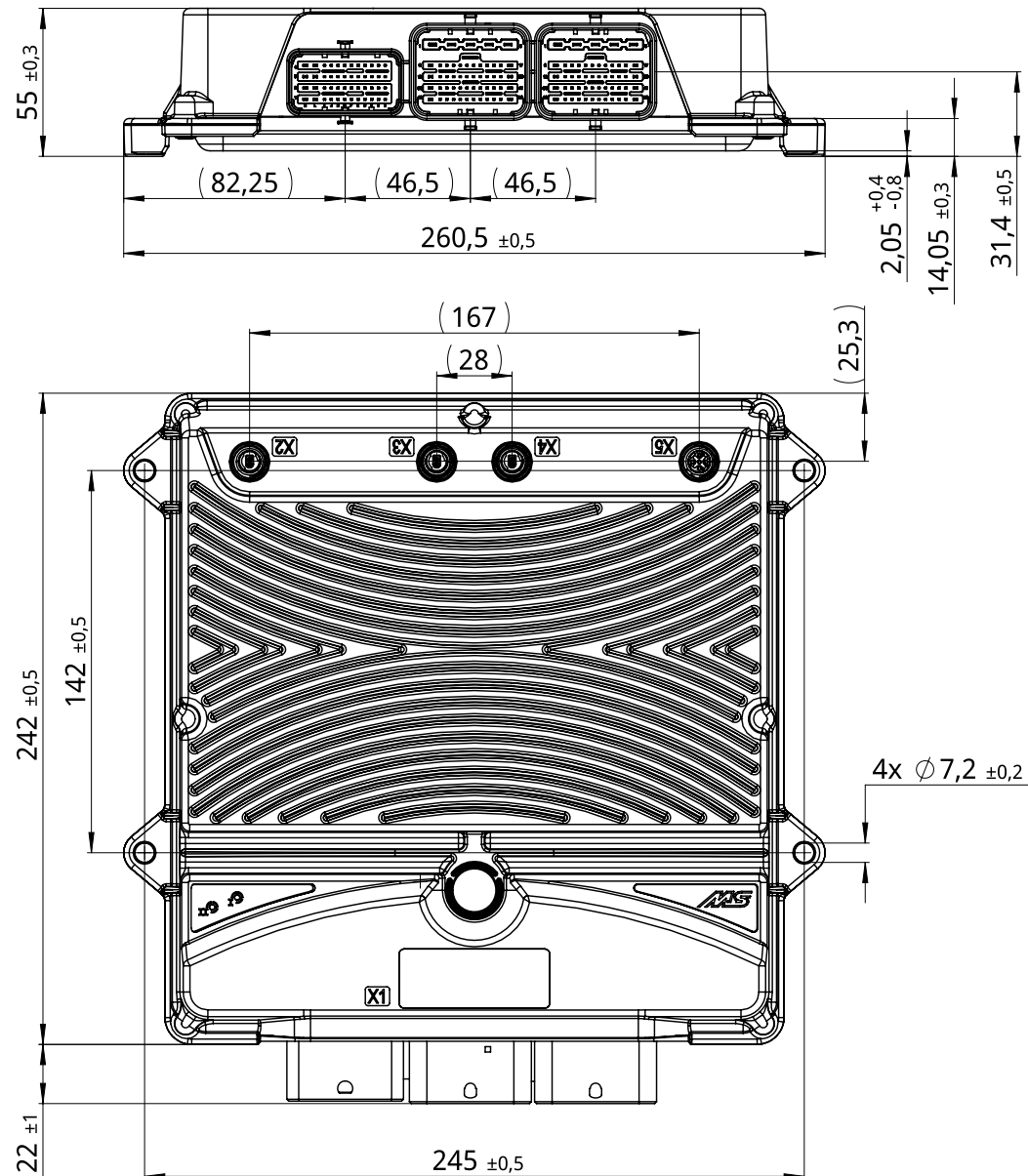

PIN ASSIGNMENT

Pin Assignment Main Connector X1 (X, Y, Z)

Variant 1

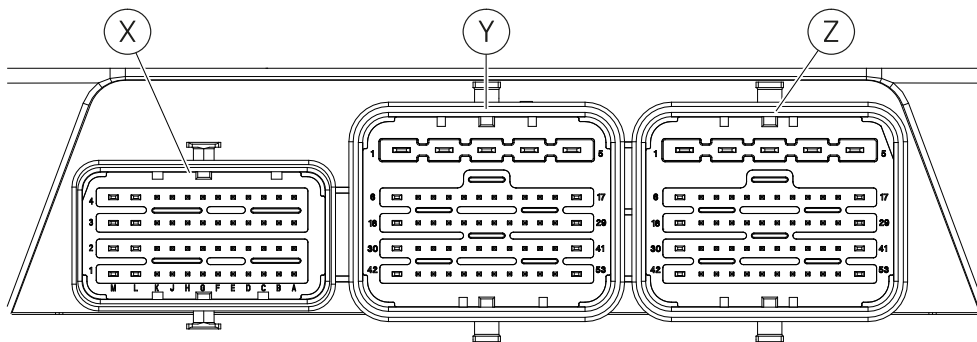

Pin Assignment Main Connector X1 (X, Y, Z)

X		Y		Z	
Pin	Signal name	Pin	Signal name	Pin	Signal name
XA1	IDSACV_8	Y1	GND_UB6	Z1	UB2
XA2	IDSACV_7	Y2	UB3	Z2	UB1
XA3	IDSACV_6	Y3	UB4	Z3	GND
XA4	IDSACV_5	Y4	UB5	Z4	GND_LS
XB1	IDA12_35V_24	Y5	UB6	Z5	UE
XB2	IDA12_35V_23	Y6	OPHSP4A_5	Z6	OPHSP4A_1
XB3	IDA12_35V_22	Y7	OPHSP2A_9	Z7	OPHSP2A_1
XB4	IDA12_35V_21	Y8	OPHSP2A_11	Z8	OPHSP2A_3
XC1	IDSACV_4	Y9	ODH2A_9	Z9	ODH2A_1
XC2	IDSACV_3	Y10	ODH2A_11	Z10	ODH2A_3
XC3	IDSACV_2	Y11	IDSACV_9	Z11	IDAC12V_1
XC4	IDSACV_1	Y12	IDA12_35V_1	Z12	IDAC12V_5
XD1	UEXT5V_2	Y13	IDA12_35V_5	Z13	IDAC12V_9
XD2	UEXT5V_1	Y14	IDA12_35V_9	Z14	IDAC12V_13
XD3	IDA12_35V_18	Y15	IDA12_35V_13	Z15	IDA12_35V_25
XD4	IDA12_35V_17	Y16	ODH2A_17	Z16	KL15
XE1	AGND	Y17	OPHB10A_1	Z17	OPL4A_1
XE2	CAN2_L	Y18	OPHSP4A_6	Z18	OPHSP4A_2
XE3	IDA12_35V_19	Y19	OPHSP2A_10	Z19	OPHSP2A_2

PIN ASSIGNMENT

Pin Assignment Main Connector X1 (X, Y, Z)

X		Y		Z	
Pin	Signal name	Pin	Signal name	Pin	Signal name
XE4	CAN1_L	Y20	OPHSP2A_12	Z20	OPHSP2A_4
XF1	AGND	Y21	ODH2A_10	Z21	ODH2A_2
XF2	CAN2_H	Y22	ODH2A_12	Z22	ODH2A_4
XF3	IDA12_35V_20	Y23	IDSACV_10	Z23	IDAC12V_2
XF4	CAN1_H	Y24	IDA12_35V_2	Z24	IDAC12V_6
XG1	UEXT5-12V_4	Y25	IDA12_35V_6	Z25	IDAC12V_10
XG2	UEXT5-12V_3	Y26	IDA12_35V_10	Z26	IDAC12V_14
XG3	CAN5_L	Y27	IDA12_35V_14	Z27	IDA12_35V_26
XG4	CAN4_L	Y28	ODH2A_18	Z28	IDA12_35V_29
XH1	AGND	Y29	OPHB10A_2	Z29	OPL4A_2
XH2	CAN3_L	Y30	OPHSP4A_7	Z30	OPHSP4A_3
XH3	CAN5_H	Y31	OPHSP2A_13	Z31	OPHSP2A_5
XH4	CAN4_H	Y32	OPHSP2A_15	Z32	OPHSP2A_7
XJ1	AGND	Y33	ODH2A_13	Z33	ODH2A_5
XJ2	CAN3_H	Y34	ODH2A_15	Z34	ODH2A_7
XJ3	CAN6_L	Y35	IDSACV_11	Z35	IDAC12V_3
XJ4	RS232/LIN Rx *	Y36	IDA12_35V_3	Z36	IDAC12V_7
XK1	UEXT5-12V_2	Y37	IDA12_35V_7	Z37	IDAC12V_11
XK2	UEXT5-12V_1	Y38	IDA12_35V_11	Z38	IDAC12V_15

Pin Assignment Main Connector X1 (X, Y, Z)

X		Y		Z	
Pin	Signal name	Pin	Signal name	Pin	Signal name
XK3	CAN6_H	Y39	IDA12_35V_15	Z39	IDA12_35V_27
XK4	RS232 Tx/ LIN Sup *	Y40	ODH2A_19	Z40	OPL0A5
XL1	AGND	Y41	ODH4A_7	Z41	OPL4A_3
XL2	ODH4A_6	Y42	OPHSP4A_8	Z42	OPHSP4A_4
XL3	ODH4A_5	Y43	OPHSP2A_14	Z43	OPHSP2A_6
XL4	ODH4A_4	Y44	OPHSP2A_16	Z44	OPHSP2A_8
XM1	AGND	Y45	ODH2A_14	Z45	ODH2A_6
XM2	ODH4A_3	Y46	ODH2A_16	Z46	ODH2A_8
XM3	ODH4A_2	Y47	IDSACV_12	Z47	IDAC12V_4
XM4	ODH4A_1	Y48	IDA12_35V_4	Z48	IDAC12V_8
		Y49	IDA12_35V_8	Z49	IDAC12V_12
		Y50	IDA12_35V_12	Z50	IDAC12V_16
		Y51	IDA12_35V_16	Z51	IDA12_35V_28
		Y52	ODH2A_20	Z52	IDA12_35V_30
		Y53	ODH4A_8	Z53	OPL4A_4

* LIN is optionally available.

PIN ASSIGNMENT

Pin Assignment Main Connector X1 (X, Y, Z)

Variant 2

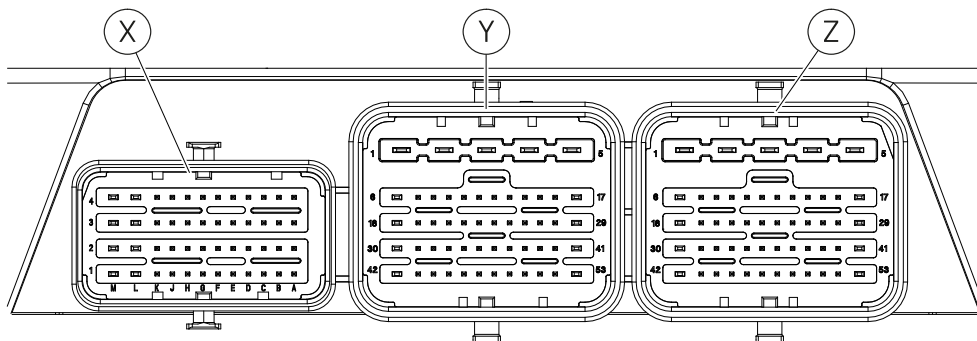

Pin Assignment Main Connector X1 (X, Y, Z)

X		Y		Z	
Pin	Signal name	Pin	Signal name	Pin	Signal name
XA1	IDSACV_8	Y1	GND_UB6	Z1	UB2
XA2	IDSACV_7	Y2	not connected	Z2	UB1
XA3	IDSACV_6	Y3	not connected	Z3	GND
XA4	IDSACV_5	Y4	UB5	Z4	GND_LS
XB1	not connected	Y5	UB6	Z5	UE
XB2	not connected	Y6	not connected	Z6	OPHSP4A_1
XB3	IDA12_35V_22	Y7	not connected	Z7	OPHSP2A_1
XB4	IDA12_35V_21	Y8	not connected	Z8	OPHSP2A_3
XC1	IDSACV_4	Y9	not connected	Z9	ODH2A_1
XC2	IDSACV_3	Y10	not connected	Z10	ODH2A_3
XC3	IDSACV_2	Y11	IDSACV_9	Z11	IDAC12V_1
XC4	IDSACV_1	Y12	IDA12_35V_1	Z12	not connected
XD1	UEXT5V_2	Y13	IDA12_35V_5	Z13	IDAC12V_9
XD2	UEXT5V_1	Y14	not connected	Z14	not connected
XD3	IDA12_35V_18	Y15	not connected	Z15	not connected
XD4	IDA12_35V_17	Y16	not connected	Z16	KL15
XE1	AGND	Y17	OPHB10A_1	Z17	OPL4A_1
XE2	CAN2_L	Y18	not connected	Z18	OPHSP4A_2
XE3	IDA12_35V_19	Y19	not connected	Z19	OPHSP2A_2

PIN ASSIGNMENT

Pin Assignment Main Connector X1 (X, Y, Z)

X		Y		Z	
Pin	Signal name	Pin	Signal name	Pin	Signal name
XE4	CAN1_L	Y20	not connected	Z20	OPHSP2A_4
XF1	AGND	Y21	not connected	Z21	ODH2A_2
XF2	CAN2_H	Y22	not connected	Z22	ODH2A_4
XF3	IDA12_35V_20	Y23	IDSACV_10	Z23	IDAC12V_2
XF4	CAN1_H	Y24	IDA12_35V_2	Z24	not connected
XG1	UEXT5-12V_4	Y25	IDA12_35V_6	Z25	IDAC12V_10
XG2	UEXT5-12V_3	Y26	not connected	Z26	not connected
XG3	CAN5_L	Y27	not connected	Z27	not connected
XG4	not connected	Y28	not connected	Z28	not connected
XH1	AGND	Y29	OPHB10A_2	Z29	OPL4A_2
XH2	not connected	Y30	not connected	Z30	OPHSP4A_3
XH3	CAN5_H	Y31	not connected	Z31	OPHSP2A_5
XH4	not connected	Y32	not connected	Z32	OPHSP2A_7
XJ1	AGND	Y33	not connected	Z33	ODH2A_5
XJ2	not connected	Y34	not connected	Z34	ODH2A_7
XJ3	CAN6_L	Y35	IDSACV_11	Z35	IDAC12V_3
XJ4	RS232/LIN Rx *	Y36	IDA12_35V_3	Z36	not connected
XK1	UEXT5-12V_2	Y37	IDA12_35V_7	Z37	IDAC12V_11
XK2	UEXT5-12V_1	Y38	not connected	Z38	not connected

Pin Assignment Main Connector X1 (X, Y, Z)

X		Y		Z	
Pin	Signal name	Pin	Signal name	Pin	Signal name
XK3	CAN6_H	Y39	IDA12_35V_15	Z39	not connected
XK4	RS232 Tx/ LIN Sup *	Y40	not connected	Z40	OPL0A5_1
XL1	AGND	Y41	not connected	Z41	not connected
XL2	ODH4A_6	Y42	not connected	Z42	OPHSP4A_4
XL3	ODH4A_5	Y43	not connected	Z43	OPHSP2A_6
XL4	ODH4A_4	Y44	not connected	Z44	OPHSP2A_8
XM1	AGND	Y45	not connected	Z45	ODH2A_6
XM2	ODH4A_3	Y46	not connected	Z46	ODH2A_8
XM3	ODH4A_2	Y47	IDSACV_12	Z47	IDAC12V_4
XM4	ODH4A_1	Y48	IDA12_35V_4	Z48	not connected
		Y49	IDA12_35V_8	Z49	IDAC12V_12
		Y50	not connected	Z50	not connected
		Y51	IDA12_35V_16	Z51	not connected
		Y52	not connected	Z52	not connected
		Y53	not connected	Z53	not connected

* LIN is optionally available.

PIN ASSIGNMENT

Connectors X2 ... X5:

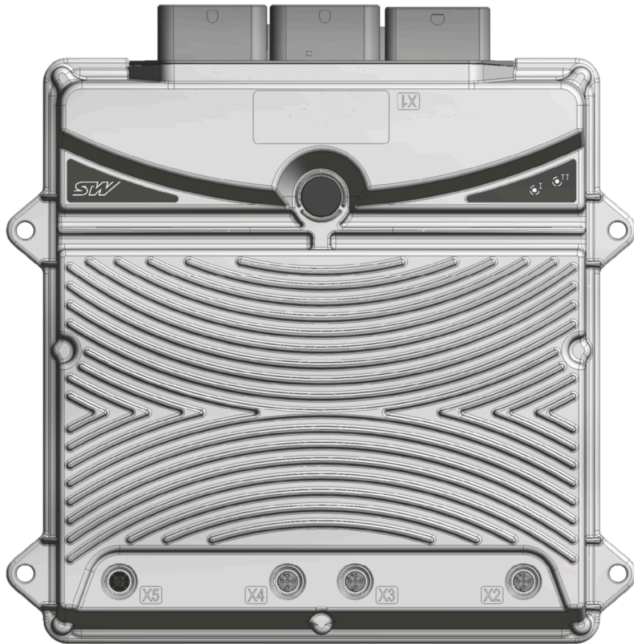

Pin Assignment M12-SPE Connectors X2 ... X4:

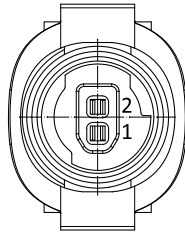

Connector X2 - Ethernet 100BASE-T1 Port1:

Pin	Description
1	ETH1_P1_BRR+
2	ETH1_P1_BRR-

Connector X3 - 100/1000BASE-T1 Port2:

Pin	Description
1	ETH1_P2_BRR+
2	ETH1_P2_BRR-

Connector X4 - Ethernet 100/1000BASE-T1 Port3:

Pin	Description
1	ETH1_P3_BRR+
2	ETH1_P3_BRR-

Pin Assignment M12, D-coded Connector X5:

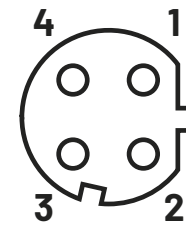

Connector X5 - Ethernet 100BASE-TX Port4:

Pin	Description
1	ETH1_P4_TX+
2	ETH1_P4_RX+
3	ETH1_P4_TX-
4	ETH1_P4_RX-

QUALIFICATION

Compliance Information

Standard	Description	Parameter
ISO/IEC 17050-1 REGULATION (EC) No 765/2008	Conformity	
UK marking	UK Conformity	
EN ISO 13849-1:2015	Safety of machinery	PL d / Cat. 2 ^{SF)}
IEC 61508:2010	Functional safety	SIL 2 ^{SF)}
ISO 11783-2:2019	CAN ISOBUS conformity	AEF conformance test Only hardware func- tionality tested.
KBA (Kraft- fahrt-Bundesamt)	Certification This approved device can be used on any vehicle type with the following restrictions: All vehicle types with a 12 V respectively 24 V - electrical wiring and battery(-) at the body	According UN ECE Regulation No. 10
2011/65/EU 2015/863/ EU	RoHS	Restriction of Hazardous Substances
2006/42/EC	Machinery directive	

SF) Scheduled feature

DETAILED QUALIFICATION

CE - EN IEC 61000-6-2:2019 (Test specifications are currently still being processed)

Standard	Test	Parameter
EN IEC 61000-6-2:2019	Immunity for industrial environments	-
	DIN EN 61000-4-2 Electrostatic discharge immunity test - direct discharges	330 Ω / 150 pF, Contact discharge ±4 kV Air discharge ±8 kV
	DIN EN 61000-4-2 Electrostatic discharge immunity test - indirect discharges (HCP, VCP)	330 Ω / 150 pF, Contact discharge ±4 kV
	DIN EN 61000-4-3 Radiated, radio-frequency, electromagnetic field immunity test	80 MHz to 1000 MHz → 10 V/m; 1.4 GHz to 6.0 GHz → 3 V/m; horizontal and vertical
	DIN EN 61000-4-4 Burst - supply lines (Electrical fast transient / burst immunity test)	±1 kV, 5/50 ns tr/th, repetition frequency 5 kHz or 100 kHz
	DIN EN 61000-4-4 Burst - data lines (Electrical fast transient / burst immunity test)	±1 kV, 5/50 ns tr/th, repetition frequency 5 kHz or 100 kHz
	DIN EN 61000-4-5 Surge - supply lines (immunity test)	asymmetrical: ±1 kV symmetrical: ±0,5 kV
	DIN EN 61000-4-5 Surge - data lines (immunity test)	asymmetrical: ±1 kV
	DIN EN 61000-4-6 Conducted immunity - supply lines (Immunity to conducted disturbances, induced by radio-frequency fields)	150 kHz to 80 MHz, 10 V
	DIN EN 61000-4-6 Conducted immunity - data lines	150 kHz to 80 MHz, 10 V

DETAILED QUALIFICATION

CE - EN IEC 61000-6-2:2019 (Test specifications are currently still being processed)

Standard	Test	Parameter
	(Immunity to conducted disturbances, induced by radio-frequency fields)	
	DIN EN 61000-4-8 magnetic field	50, 60 Hz, 30 A/m
EN 61000-6-4:2007 + A1:2011	Emission standard for industrial environments	Conducted (CE) 0.15 MHz ... 30 MHz Radiated (RE) 30 MHz ... 1000 MHz (6000 MHz) 10 m

DETAILED QUALIFICATION

Functional Safety - DIN EN 61326-3-1 (Test specifications are currently still being processed)

Standard	Test	Parameter
DIN EN 61326-3-1:2018	Tabelle 2 DIN EN 61000-4-2 - direct discharges Electrostatic discharge immunity test	330 Ω / 150 pF, Contact discharge ±6 kV Air discharge ±8 kV
	Tabelle 2 DIN EN 61000-4-2 - indirect discharges Electrostatic discharge immunity test	330 Ω / 150 pF, Contact discharge ±6 kV
	Tabelle 2 DIN EN 61000-4-3 Radiated, radio-frequency, electromagnetic field immunity test	80 MHz to 1000 MHz, 20 V/m; 1,4 GHz to 2 GHz, 10 V/m 2,0 GHz to 2,7 GHz → 3 V/m; horizontal, vertical
	Tabelle 2 DIN EN 61000-4-8 magnetic field	30 A/m (No higher test levels will be applied)
	Tabelle 4 DIN EN 61000-4-4 Burst - supply lines (Electrical fast transient / burst immunity test)	±3 kV, 5/50 ns tr/th, repetition frequency 5 kHz
	Tabelle 5 DIN EN 61000-4-4 Burst - data lines (Electrical fast transient / burst immunity test)	±2 kV, 5/50 ns tr/th, repetition frequency 5 kHz
	Tabelle 4 DIN EN 61000-4-5 Surge - supply lines (immunity test)	asymmetric: ±2 kV symmetric: ±1 kV
	Tabelle 5 DIN EN 61000-4-5 Surge - data lines (immunity test)	asymmetric: ±2 kV

DETAILED QUALIFICATION

Functional Safety - DIN EN 61326-3-1 (Test specifications are currently still being processed)

Standard	Test	Parameter
	Tabelle 4 DIN EN 61000-4-6 Conducted immunity - supply lines (Immunity to conducted disturbances, induced by radio-frequency fields)	150 kHz to 80 MHz, 10 V
	Tabelle 5 DIN EN 61000-4-6 Conducted immunity - data lines (Immunity to conducted disturbances, induced by radio-frequency fields)	150 kHz to 80 MHz, 10 V
	Tabelle 4 IEC 61000-4-16 Conducted common-mode voltages Supply lines	1 V to 10 V, 20 dB/Decade (1,5 kHz to 15 kHz) 10 V (15 kHz to 150 kHz) 10 V (constant with direct current, 16 ² / ₃ Hz, 50 / 60 Hz and 150 / 180 Hz) 100 V short period (1 s, with direct current, 16 ² / ₃ Hz and 50 / 60 Hz)
	Tabelle 5 IEC 61000-4-16 Conducted common-mode voltages signal lines	1 V to 10 V, 20 dB/Decade (1,5 kHz to 15 kHz) 10 V (15 kHz to 150 kHz) 10 V (constant with direct current, 16 ² / ₃ Hz, 50 / 60 Hz and 150 / 180 Hz) 100 V short period (1 s, with direct current, 16 ² / ₃ Hz and 50 / 60 Hz)
	Tabelle 4 IEC 61000-4-29 Votlage dips (Supply lines)	40 % U _T during 10 ms
	Tabelle 4 IEC 61000-4-29 Short interruptions (Supply lines)	0 % U _T during 20 ms

DETAILED QUALIFICATION

E1 - ECE R10 (Test specifications are currently still being processed)

Standard	Test	Parameter
UN ECE R10 Add. 9, Rev. 6 Annex 7	Radiated broadband emissions from ESAs CISPR25:2004	30 MHz ... 1000 MHz
UN ECE R10 Add. 9, Rev. 6 Annex 8	Radiated narrowband emissions from ESAs CISPR25:2004	30 MHz ... 1000 MHz
UN ECE R10 Add. 9, Rev. 6 Annex 9	Immunity of ESAs to electromagnetic radiation General: ISO 11452-1:2005 ALSE: ISO 11452-2:2004 BCI: ISO 11452-4:2011 (Stripline and TEM alternative test methods)	General 20 MHz ... 2000 MHz 20 MHz ... 800 MHz: AM 800 MHz ... 2000 MHz: PM BCI: 20 MHz ... 400 MHz, 60 MA (substitution (150 Mm) or closed loop (900 Mm) method allowed) Antenne, ALS E (vert): 200 MHz ... 800 MHz, 30 V/m, AM 800 MHz ... 2000 MHz, 30 V/m, PM
UN ECE R10 Add. 9, Rev. 6 Annex 10	Conducted transient emission from ESAs on 12 V supply lines ISO 7637-2:2004	slow/fast: pos: +75 V neg: -100 V
	Conducted transient emission from ESAs on 24 V supply lines ISO 7637-2:2004	slow/fast: pos: +150 V neg: -450 V
	Electrical transient conduction along supply lines 12V System, Level 3 ISO 7637-2:2004	Pulse 1 - 75V, 5000 pulses t1 = 0,5 s to 5 s Pulse 2a 37V, 5000 pulses t1 = 0,2 s to 5 s

DETAILED QUALIFICATION

E1 - ECE R10 (Test specifications are currently still being processed)

Standard	Test	Parameter
		Pulse 2b 10 V, 10 pulses td = 0,2 s to 2 s
		Pulse 3a -112 V, 1 hr
		Pulse 3b 75 V, 1 hr
		Pulse 4 Us = -6 V Ua = -2,5 V to -6V 1 pulse
	Electrical transient conduction along supply lines 24V System, Level 3 ISO 7637-2:2004	Pulse 1 -450 V, 5000 pulses t1 = 0,5 s to 5 s
		Pulse 2a 37 V, 5000 pulses t1 = 0,2 s to 2 s
		Pulse 2b 20 V, 10 pulses td = 0,2 s to 2 s
		Pulse 3a -150 V, 1 hr
		Pulse 3b +150 V, 1 hr
		Pulse 4 Us = -12 V Ua = -5 V to -12 V 1 pulse

DETAILED QUALIFICATION

Electrical Safety (Test specifications are currently still being processed)

Standard	Test	Parameter
ISO 16750-2:2012-11	Direct current supply voltage	Operation at T _{max} with maximum and minimum voltage Operation at T _{min} with maximum and minimum voltage
	Overvoltage - Systems with 12 V / 24 V nominal voltage - 12 V Systems	18 V for 60 min. at 20 °C below T _{max} 24 V for 60 s at room temperature
	Overvoltage - Systems with 12 V / 24 V nominal voltage - 24 V Systems	36 V for 60 min. at 20 °C below T _{max}
	Superimposed alternating voltage - 12 V Systems	U _{smax} = 16 V (for U _N = 12 V) Sweep duration: 120 seconds Number of sweeps: 5 Severity 1, 2, 4
	Superimposed alternating voltage - 24 V Systems	U _{smax} = 32 V (for U _N = 24 V) Sweep duration: 120 seconds Number of sweeps: 5 Severity 1, 2, 3
	Slow decrease and increase of supply voltage	Decrease supply voltage from U _{smin} to 0 V and increase it from 0 V to U _{smin} . Applying a change rate of (0.5 ± 0.1) V per minute
	Discontinuities in supply voltage - Momentary drop in supply voltage - 12 V Systems	Drop to 4.5 V for ≤ 100 ms
	Discontinuities in supply voltage - Momentary drop in supply voltage - 24 V Systems	Drop to 9 V for ≤ 100 ms
	Discontinuities in supply voltage - Reset behavior voltage drop	Decrease supply voltage from U _{smin} in 5 % steps
	Discontinuities in supply voltage - Starting profile 12 V code C	Voltage cranking; Level 1 Voltage cranking; Level 2

DETAILED QUALIFICATION

Electrical Safety (Test specifications are currently still being processed)

Standard	Test	Parameter
		Voltage cranking; Level 3
		Voltage cranking; Level 4
	Discontinuities in supply voltage - Starting profile 24 V code E	Voltage cranking; Level 1
		Voltage cranking; Level 2
		Voltage cranking; Level 3
	Discontinuities in supply voltage-Load Dump - Pulse B - 12 V System	with centralized load dump suppression 5 Pulses
	Discontinuities in supply voltage-Load Dump - Pulse B - 24 V System	with centralized load dump suppression 5 Pulses
	Reversed voltage - Case 1 - 12 V Systems	Unom. = 12 V → Case 1 - Test Voltage = -4 V reversed polarity Duration: 60 s
	Reversed voltage - Case 2 - 12 V Systems	Unom. = 12 V → Case 2 - Test Voltage = -14 V reversed polarity Duration: 60 s
	Reversed voltage - Case 2 - 24 V Systems	Unom. = 24 V → Case 2 - Test Voltage = 28 V reversed polarity Duration: 60 s
	Ground reference and supply offset - 12 V Systems	±1 V offset; only required if two or more power supplies exist; Low-Side-Sensor must be connected to ground point at ECU connector
	Ground reference and supply offset - 24 V Systems	±1 V offset; only required if two or more power supplies exist; Low-Side-Sensor must be connected to ground point at ECU connector
	Open circuit tests - Single line interruption - 12 V Systems	Interruption of each single Output for (10 ±1) s.
	Open circuit tests - Single line interruption - 24 V Systems	Interruption of each single Output for (10 ±1) s.
	Open circuit tests - Multiple line interruption - 12 V Systems	Disconnect the DUT for (10 ±1) s.

DETAILED QUALIFICATION

Electrical Safety (Test specifications are currently still being processed)

Standard	Test	Parameter
	Open circuit tests - Multiple line interruption - 24 V Systems	Disconnect the DUT for (10 ±1) s.
	Short circuit protection - signal circuits	Connect every In- and Output to maximum supply voltage (Usmax) and Ground for 1 minute various modes necessary
	Short circuit protection - load circuits (supply lines)	to load circuits

Electromagnetic Compatibility (E1)(Test specifications are currently still being processed)

Standard	Test	Parameter
ISO 7637-2: 2011	Conducted transient emission from ESAs on 12 V supply lines, Level 3 ISO 7637-2:2011	slow+: +37 V slow-: -75 V fast+: +75 V fast-: -112 V
	Conducted transient emission from ESAs on 24 V supply lines, Level 3 ISO 7637-2:2011	slow+: +37 V slow-: -150 V fast+: +150 V fast-: -150 V
	Electrical transient conduction along supply lines -24 V System, Level 4	Pulse 1 -600 V, 500 pulses t1 ≥ 0,5 s
		Pulse 2a +112 V, 500 pulses t1 = 0,2 s to 5 s
		Pulse 2b +20 V, 10 pulses td = 0,2 s to 2 s
		Pulse 3a -300 V, 1 h
		Pulse 3b +300 V, 1 h

DETAILED QUALIFICATION

Environmental Qualification (Test specifications are currently still being processed)

Standard	Test	Parameter
ISO 16750-3:2012	Resonance search	10Hz - 2000Hz, 1g, 0.5 oct/min
	Test VII - Commercial vehicle, sprung masses	Vibration noise with temperature superimposition in case of natural frequencies of DUT upper 30 Hz: random vibration acc IEC60068-2-64 from 10 Hz to 2000 Hz for 32 hrs each axis, Temperature cycle 8h from Tmin to Tmax
	Test VII - Commercial vehicle, sprung masses, Additional profile in the case of DUT natural frequencies < 30 Hz (Test VII)	Random vibration acc IEC60068-2-64 from 10 Hz to 45 Hz for 32 hrs each axis, Temperature cycle 8 h from Tmin to Tmax
	Mechanical Shock - Test for devices on rigid points on the body and on the frame	In acc. IEC 60068-2-27 half-sinusoidal Acceleration 500 m/s ² Duration 6 ms room temperature 10 shocks per test direction
	Free fall (parts that may withstand falling without damages)	3 devices, 2 falls every device on the opposite side of the housing. Drop height: 1 m to concrete ground or steel plate
ISO 16750-4:2010	Tests at constant temperature: Low temperature - storage	- 40 °C for 24 hrs
	Tests at constant temperature: Low temperature - operation	Tmin for 24 hrs
	Tests at constant temperature: High temperature - storage	85 °C for 48 hrs
	Tests at constant temperature: High temperature - operation	Tmax for 96 hrs
	Temperature step test	20 °C to Tmin to Tmax, 5 °C steps; *Perform functional tests (OM 3.2) when DUT has reached the new temperature with Usmin and Usmax

DETAILED QUALIFICATION

Environmental Qualification (Test specifications are currently still being processed)

Standard	Test	Parameter
	Temperature cycling test	acc. to IEC 60068-2-14, Test Nb 30 cycles á 480 min , Tmin to Tmax Duration: 10 days *OM 3.2 for phases with electrical operation
	Temperature cycling test - Rapid change of Temperature	acc. to IEC 60068-2-14, Test Na Transfer time ≤ 30 sec.
	Ice water shock test - Splash water test	Heat the DUT at Tmax for the specified holding time t_h , then splash it with ice water (0 °C to +4 °C) for 3 sec.; (t_h = 1 hr or until temp. Stabilization is reached) 100 cycles each 66 Min.
	Salt spray test - Corrosion test	acc to IEC60068-2-52, Test Kb
	Salt spray test - Leakage and function	acc to IEC60068-2-11, Ka; 8h salt spray and 16h without spray, minimum 6 cycles á 24 hrs
	Humid heat cyclic - Test 2: Composite temperature / humidity cyclic test	acc to IEC60068-2-38, -Z/AD 10 cycles, upper temperature +65°C 93% r.H. 5 cycles with frost phase (-10°C); Duration: 11 days *OM 3.2 when the maximum cycle temperature is reached;
	Humid head cyclic - Test 3: Dewing test	In acc. To IEC 60068-2-38, Test Db Upper Temp.: 80°C, 5 cycles
	Damp heat, steady-state test	acc to IEC60068-2-78; +40°C and 85% r.H. OM: 2.1 for 20 days 23 hrs OM: 3.2 for the last hour Duration: 21 days
	Corrosion test with flow of mixed gas	acc to IEC60068-2-60, Test Ke, method 4; (SO2, H2S, NO2, CL2) 10 days (mounting passenger or luggage/load compartment) 21 days (other mounting locations)

DETAILED QUALIFICATION

Environmental Qualification (Test specifications are currently still being processed)

Standard	Test	Parameter
	Solar radiation	Confirmation of housing- and plug manufacturer about UV and OZON durability or test e.g. ISO 75220 or DIN EN 60068-2-5
	Dust Test	Acc. To ISO 20653 but different dust 50% limestone 50% fly ash (33% < 32 µm, 67% >32 µm but <250 µm) 20 cycles
	Protection against dust and water	ISO 20653
ISO 16750-5:2010	Chemical resistance	Exposure time 24 h, Exposure condition. 20 °C, 85% relative humidity, Gasoline, Methanol, Battery acid, Protective lacquer, Windshield washer fluid, Vehicle washing chemicals, Cold cleaning agent, Cleaning solvent, Denatured alcohol, Runway deicer, Aceton
		Exposure time 24 h Exposure. 125 °C, 85% rel. humidity Diesel fuel, Diesel fuel "Bio", Engine oil, Transmission fluid, Automatic transmission oil, Hydraulic oil, Greases, Silicone oil, Brake fluid, Antifreeze fluid, Urea, Protective lacquer remover, Contact spray
ISO 20653: 2013-02	IP Protection	IP6KX, IPX7, IPX9K IPX9K: This IP protection class only applies to variants that have a housing without M12 connector.
ISO 4892-2:2013-06	Exposure from Xenon-arc lamps	Method A - Testing with filters for global radiation - Cycle no. 1, table 3)
DIN EN 50102:1997-09	Degrees of protection provided by enclosures for electrical equipment against external mechanical impacts (IK code).	IK7 Impact energy (joules): 2